

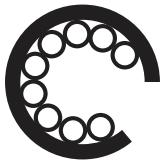

**Gas Struts**



**Ball Bearing Slides**



**Latch Lock Drawers**

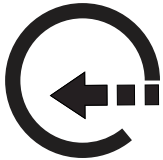

**Firm Close Drawers**



**Key Lock**



Edition : 1.0  
Date: (1/25)

# Instruction Manual

## DELUXE SERIES STEEL SERVICE CART SDC-5E

Order Code: (T755)

# STEEL SERVICE CART

## DELUXE SERIES



### BEFORE ASSEMBLING

Please read this instruction manual before assembly.



#### **CAUTION**

Before assembly please pay attention to the following points in priority;

**Confirmation of components:** Before assembling, please confirm all parts arrived and are in good order.

**Site for assembly:** Please assemble it on the soft floor such as smooth carpet and flannel blanket. When you assemble on wooden floor, please put thin towels on the floor.

**Points for attention when assembling:** Please wear gloves to ensure that it can be assembled safely, and use two persons to help in the assembly process.

### SAFETY INFORMATION

1. Do not pull this service cart , push it when moving.
2. Engage both brakes when this service cart is not being moved. This prevents the service cart rolling away.
3. Secure this service cart properly before moving with a forklift.
4. Do not tow this service cart with power equipment.
5. Do not alter this service cart in any manner. For Example. Do not weld external lock bars or attach electrical equipment.
6. Before locking the service cart , ensure the drawers are completely closed in order for the lock bars to work properly.



**CAUTION:** Do not attach or mount this product to a vehicle. This may cause personal injury or product damage. Mounting this product to any vehicle in any manner will void warranty.



**CAUTION:** Keep the product on level surfaces. The product may become unstable and tip if stored or moved on an un-level surface, which may cause personal injury or product damage.



**CAUTION:** Do not stand on this product. You may fall which may cause personal injury or product damage.



**CAUTION:** Lock the drawers before moving this product. The drawers could come open and make the product unstable and tip, which may cause personal or product damage.



**CAUTION:** Be careful when opening more than one drawer. The product may become unstable and tip, which may cause personal injury or product damage.



# STEEL SERVICE CART DELUXE SERIES



## SPECIFICATIONS

Overall size lid closed:.. 865 x 510 x 1050mm (LxWxH)

Overall size lid open: .... 865 x 510 x 1570mm (LxWxH)

Top compartment area: 650 x 480 x 120mm (LxWxD)  
80kg load capacity

Drawer 1 & 2:..... 285 x 425 x 50mm (LxWxD)  
20kg load capacity each

Drawer 3:..... 285 x 425 x 120mm (LxWxD)  
40kg load capacity

Drawer 4: ..... 620 x 425 x 70mm (LxWxD)  
40kg load capacity

Drawer 5: ..... 620 x 425 x 120mm (LxWxD)  
40kg load capacity

Open bottom tray: ..... 755 x 485 x 85mm (LxWxD)  
80kg load capacity

Open side tray: ..... 485 x 95 x 85mm (LxWxD)

Nett Weight: 61.6kg

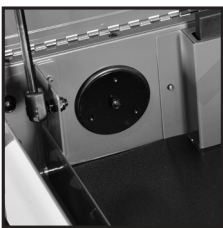
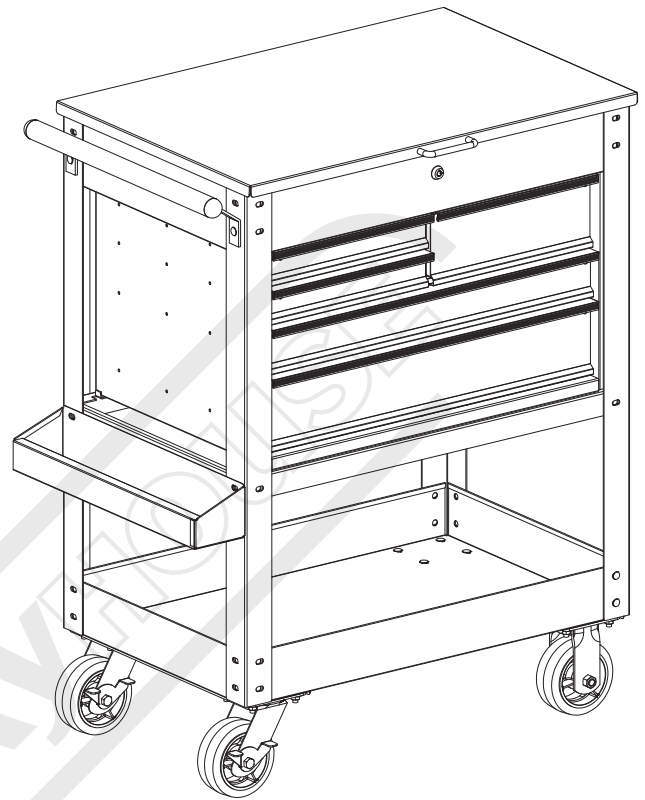

Cable Access  
Points (x1)



Gas Struts (x2)

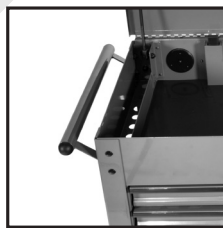

Heavy Duty  
Handle (x1)



Keys (x4)

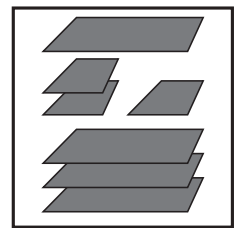

Foam Liners (x7)

## KEY / LOCKING OPERATION

**KEY LOCK** - will lock the entire tool chest and drawers

**LID CLOSED** - will lock drawers via the rear locking system

# STEEL SERVICE CART DELUXE SERIES



## DRAWER REMOVAL / RE-INSERTING

1.

### Removing the drawers

- Fully extend the empty drawer.
- Push up the one release lever while pulling down on the other release lever.
- Pull the drawer outward until it is released from the drawer slide.

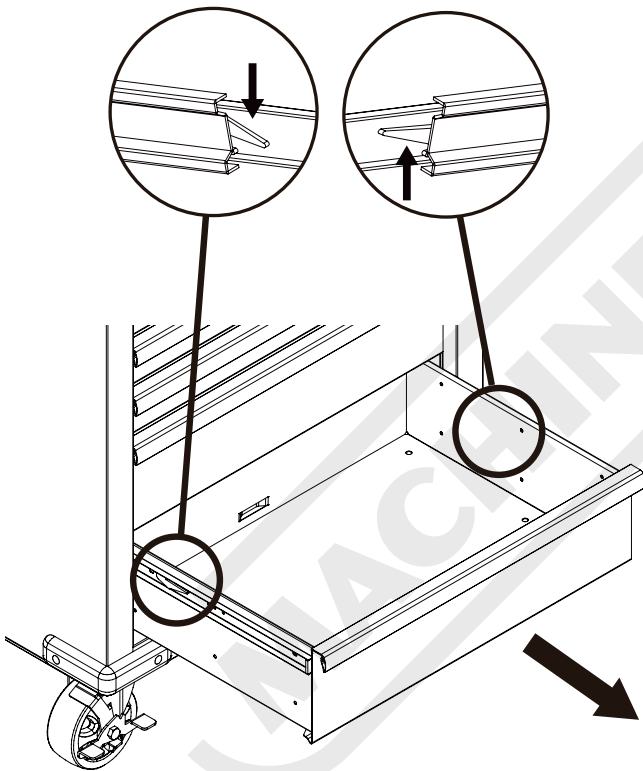

2.

### Re-inserting the drawers

- Extend the drawer slides.
- Insert the brackets on each side of the drawer into the slots in the slides, being careful that they are properly positioned.
- Once properly inserted, completely close the drawer to set the slides in their proper positions and make sure you go all the way in to engage the firm close drawer system.

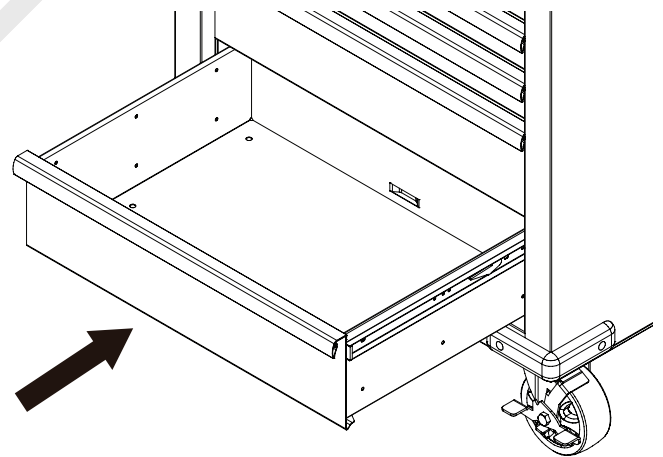

NOTE: Image is for illustrative purpose only and may not be an exact representation of the product.

## MAINTENANCE

1. Wheel maintenance: Grease the wheels annually using high-quality bearing grease.
2. Drawer maintenance: Lubricate the slides semi-annually with high-quality bearing grease.
3. Lubricate the lock with graphite annually.

# STEEL SERVICE CART

## DELUXE SERIES



Carefully unpack and spread out all parts in a large uncluttered area. Familiarize yourself with all parts and compare them with the drawing below to make sure none are missing. Read all assembly instructions before beginning.

### PARTS LIST

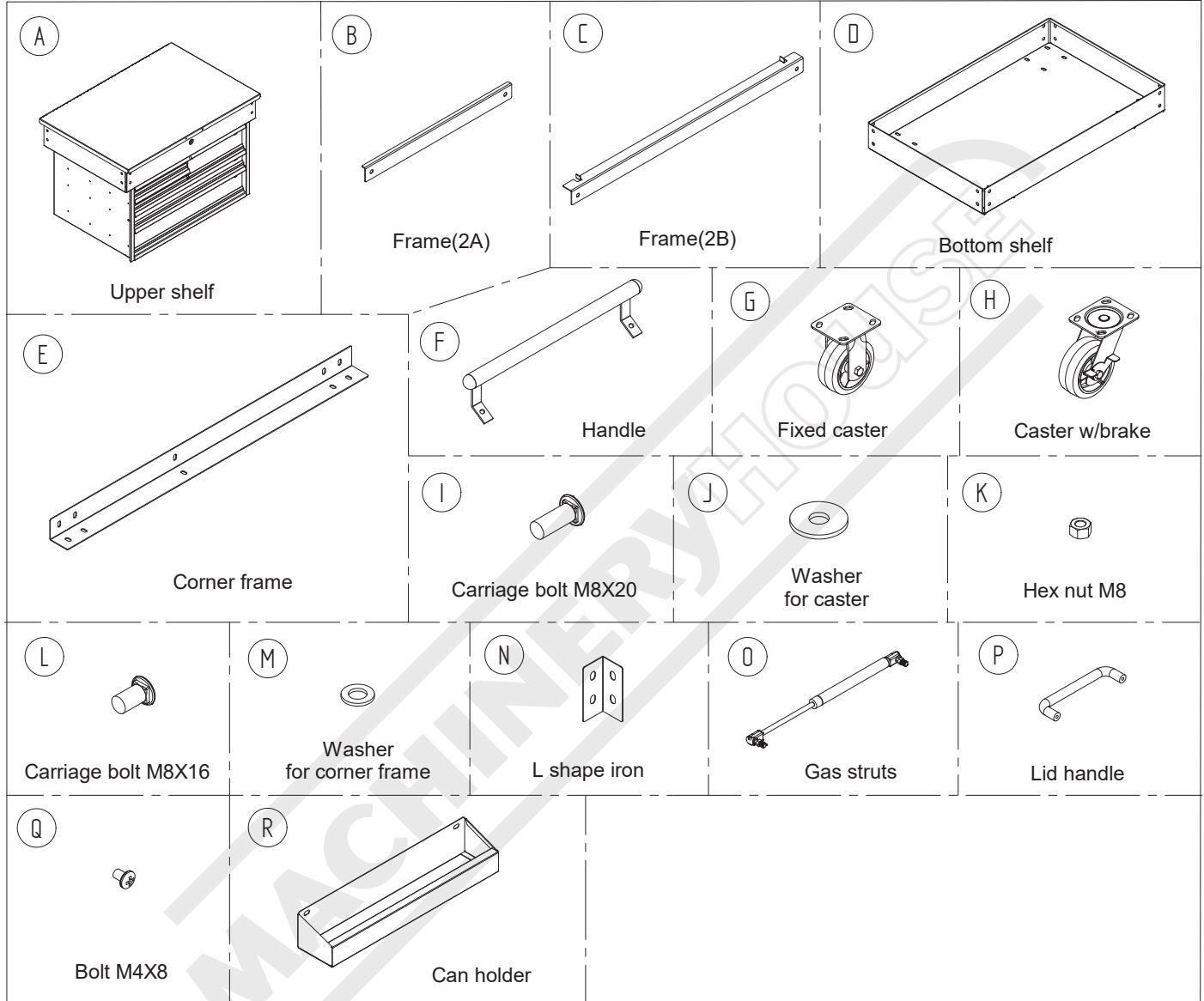

Item	Description	Q'ty	Item	Description	Q'ty	Item	Description	Q'ty
A	Upper shelf	1	G	Fixed caster	2	M	Washer for corner frame	40+2
B	Frame(2A)	2	H	Caster w/brake	2	N	L shape iron	4
C	Frame(2B)	2	I	Carriage bolt M8X20	18+1	O	Gas struts	2
D	Bottom shelf	1	J	Washer for caster	16+1	P	Lid handle	1
E	Corner frame	4	K	Hex nut M8	60+3	Q	Bolt M4X8	2
F	Handle	1	L	Carriage bolt M8X16	38+2	R	Can holder	1

**TOOLS REQUIRED :** #2 and #3 phillips screwdrivers  
13mm wrench or socket for caster nuts and corner frame nuts

# STEEL SERVICE CART DELUXE SERIES



## ASSEMBLY INSTRUCTIONS

### TOOLS & ASSISTANCE NEEDED

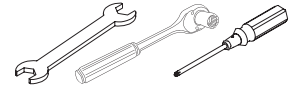

13mm Spanner or Socket Wrench  
#2 & #3 Philips Head Screwdrivers

\*Tools not included

### STEP 1

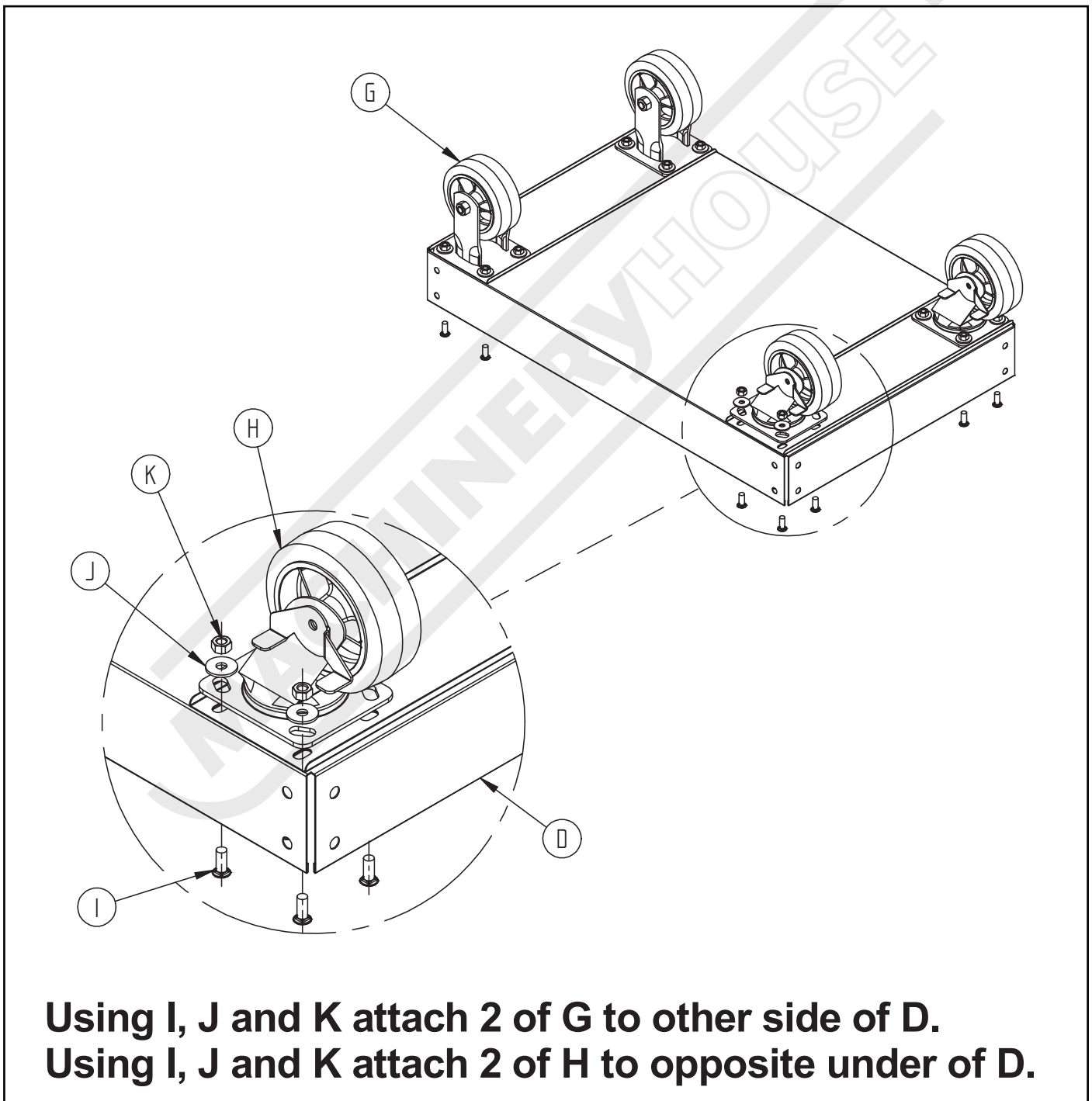

Using I, J and K attach 2 of G to other side of D.  
Using I, J and K attach 2 of H to opposite under of D.

# STEEL SERVICE CART DELUXE SERIES



## ASSEMBLY INSTRUCTIONS Cont..

### STEP 2

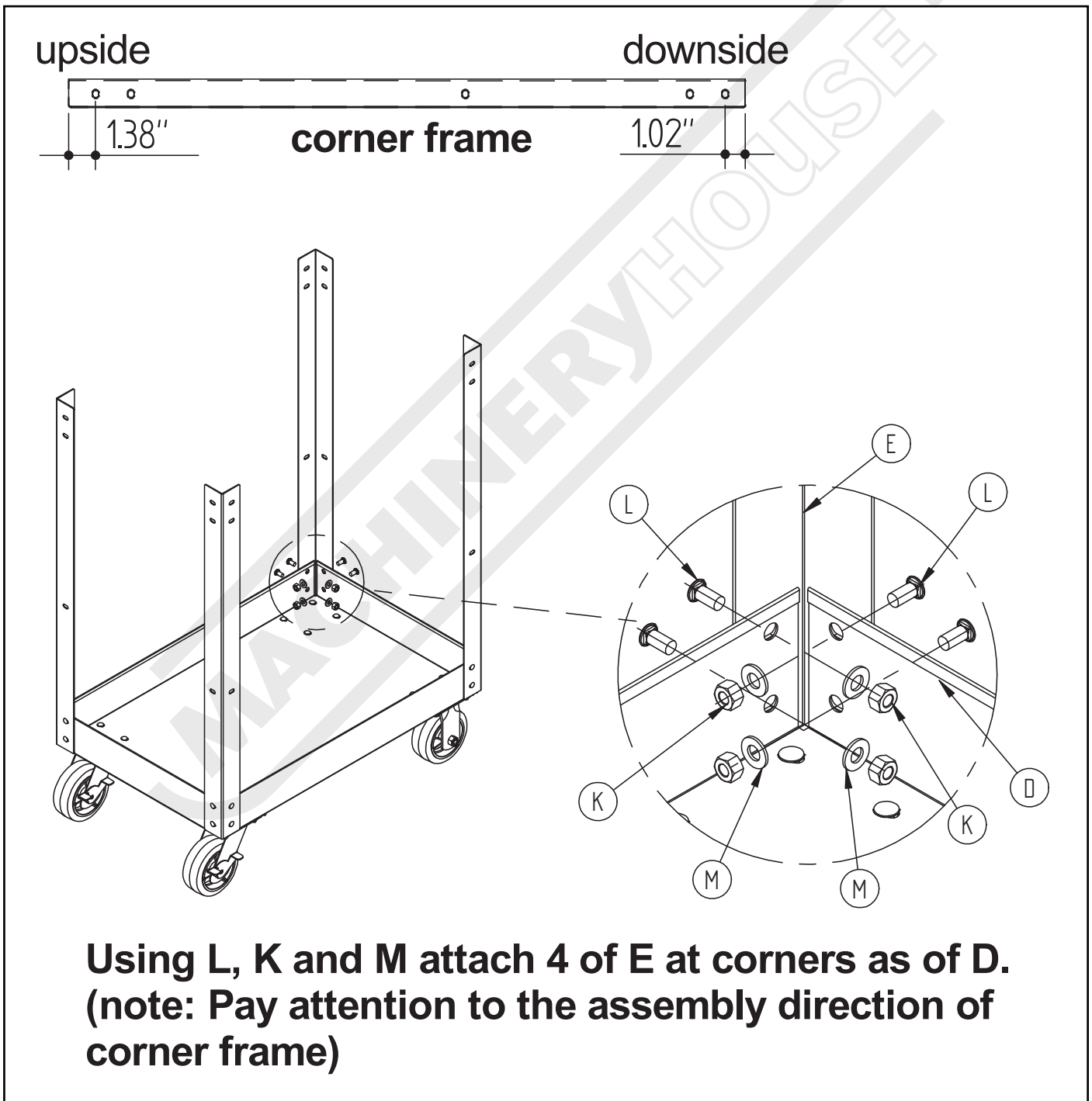

# STEEL SERVICE CART DELUXE SERIES



## ASSEMBLY INSTRUCTIONS Cont...

### STEP 3

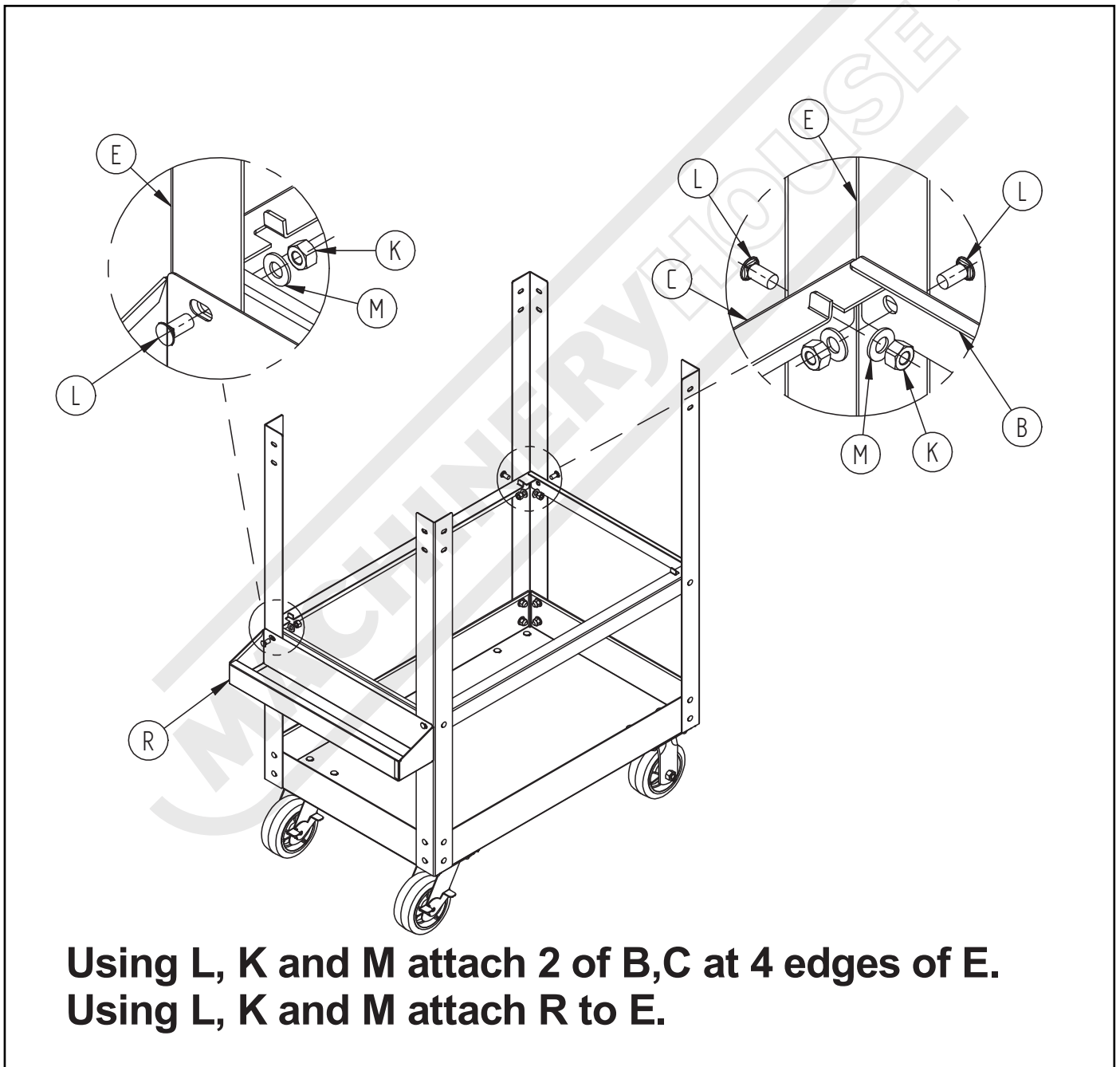



# STEEL SERVICE CART DELUXE SERIES



## ASSEMBLY INSTRUCTIONS Cont...

### STEP 4

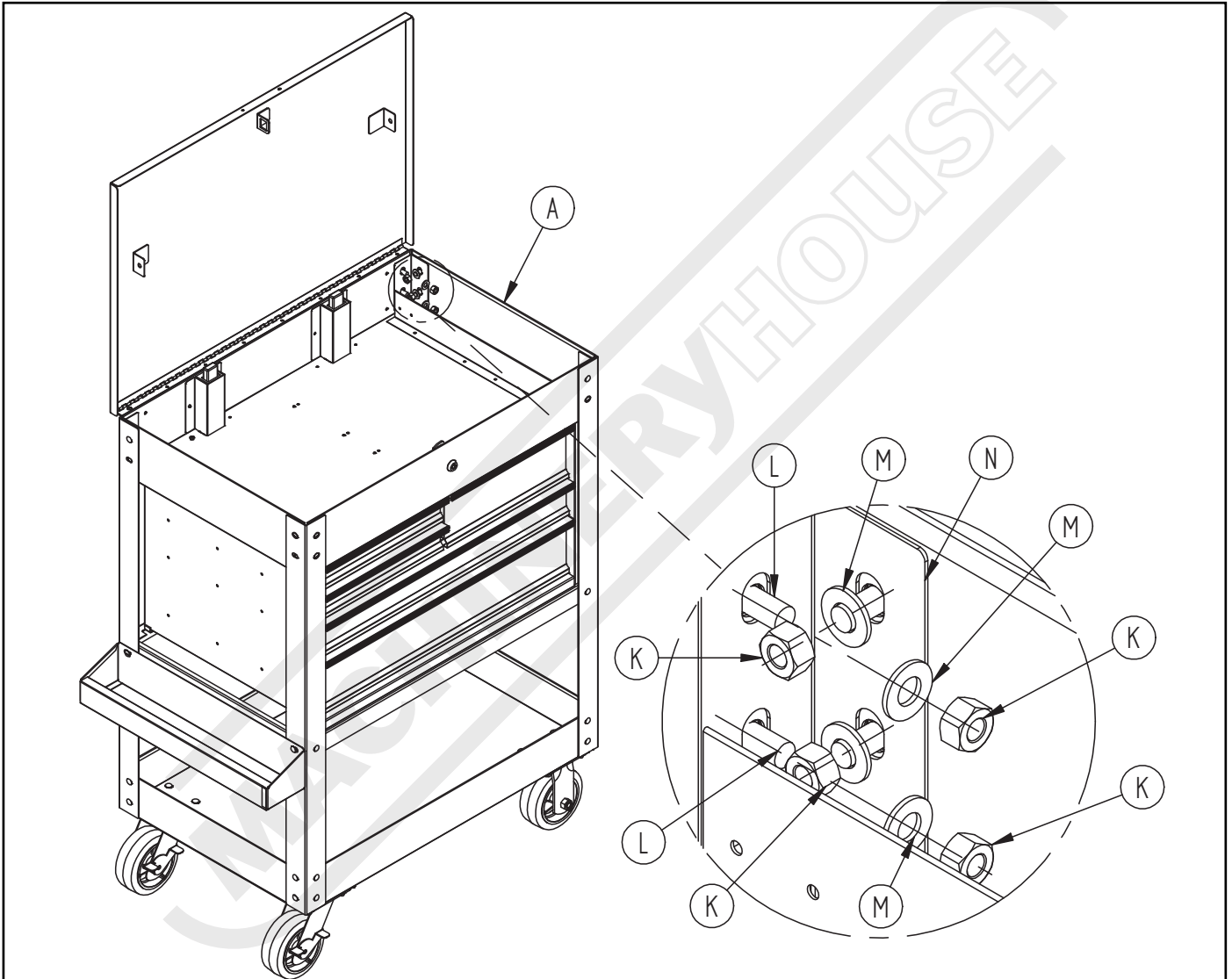

**Place A on the E edges top, and add 4 of N at 4 corners, using L lower case letters and K, M to fix it. (note: leave 2 holes open for handle)**

# STEEL SERVICE CART DELUXE SERIES



## ASSEMBLY INSTRUCTIONS Cont...

### STEP 5

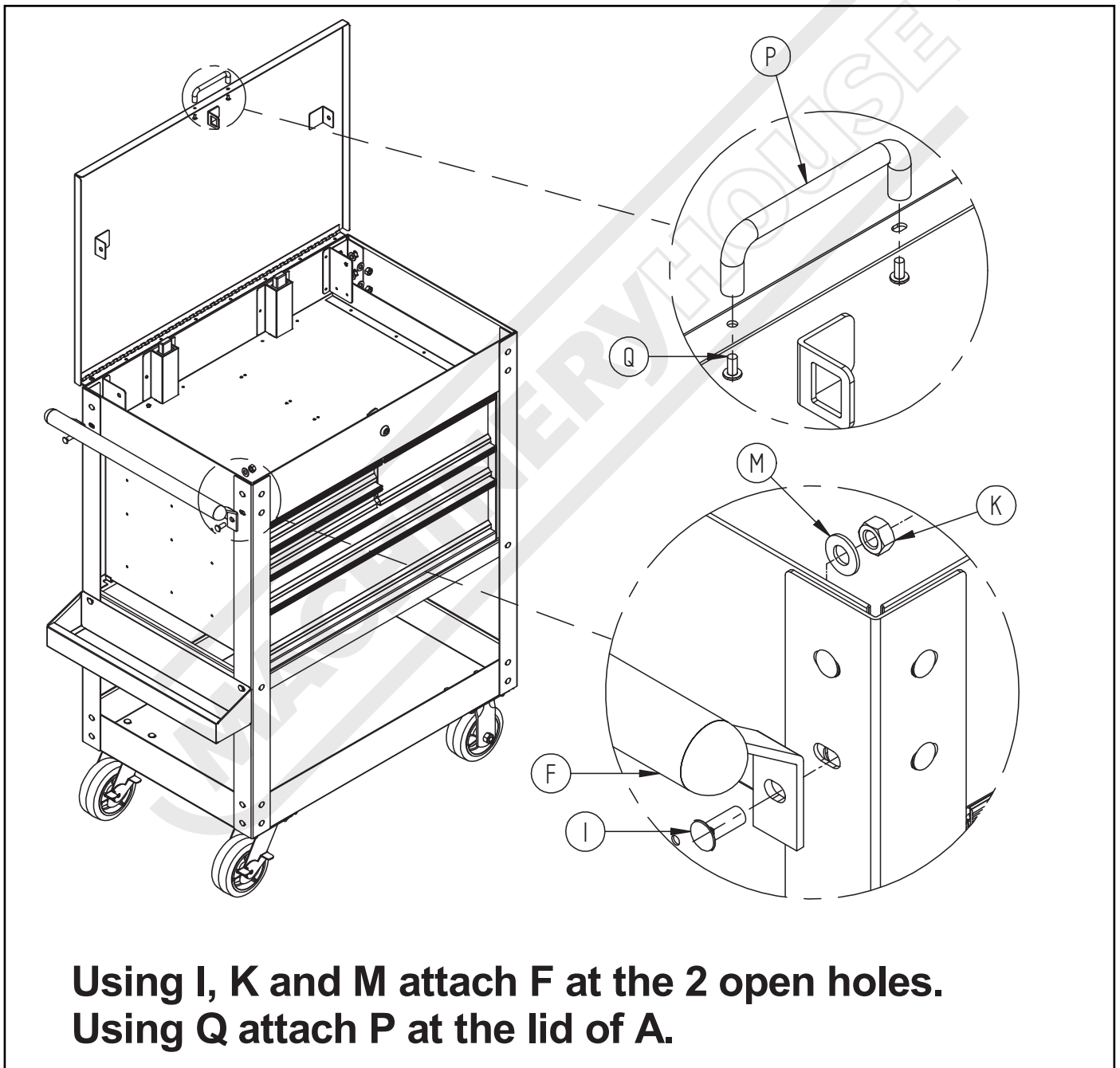

# STEEL SERVICE CART DELUXE SERIES



## ASSEMBLY INSTRUCTIONS Cont...

### STEP 6

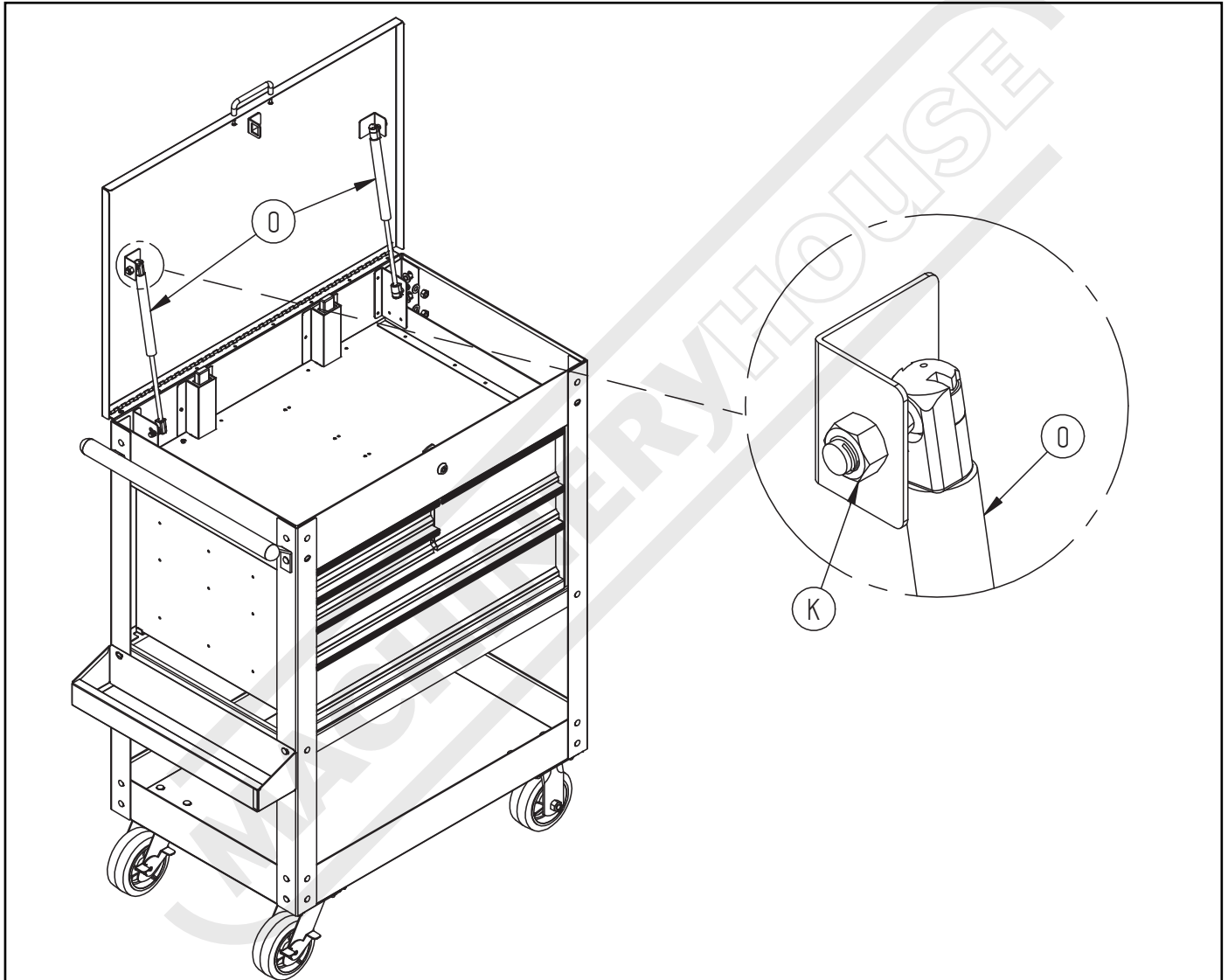

**Using K attach 2 of O to A. Now you can tighten nuts/bolts fully starting from the bottom to the top.**



#### **ENVIRONMENT PROTECTION**

Recycle unwanted materials instead of disposing of them as waste. All tools, accessories and packaging should be sorted, taken to a recycling centre and disposed of in a manner which is compatible with the environment. When the product becomes completely unserviceable and requires disposal, drain any fluids (if applicable) into approved containers and dispose of the product and fluids according to local regulations.

Imported by

**HARE & FORBES**  
**MACHINERYHOUSE**

**Australian Distributor**

Hare & Forbes  
Machineryhouse  
Sydney - Melbourne  
Adelaide - Brisbane - Perth

Ph: 1300 202 200  
[www.machineryhouse.com.au](http://www.machineryhouse.com.au)

**MACHINERYHOUSE**

**New Zealand Distributor**

Machineryhouse  
Auckland  
Christchurch

Ph: 0800 142 326  
[www.machineryhouse.co.nz](http://www.machineryhouse.co.nz)